



MASON INDUSTRIES, Inc.
Manufacturers of Vibration Control Products

350 Rabro Drive 2101 W. Crescent Ave., Suite D
Hauppauge, NY 11788 Anaheim, CA 92801
631/348-0282 714/535-2727
FAX 631/348-0279 FAX 714/535-5738
Info@Mason-Ind.com Info@MasonAnaheim.com
www.Mason-Ind.com www.MasonAnaheim.com

CERTIFIED FOR _____

JOB NAME _____

CUSTOMER _____

CUSTOMER P.O. _____

MASON M. _____

DWG No. _____

TYPE

SLF

50mm DEFLECTION
B, B2, C2 & 2-C2 Series
SPRING MOUNTS

SLF-B,B2 & C2

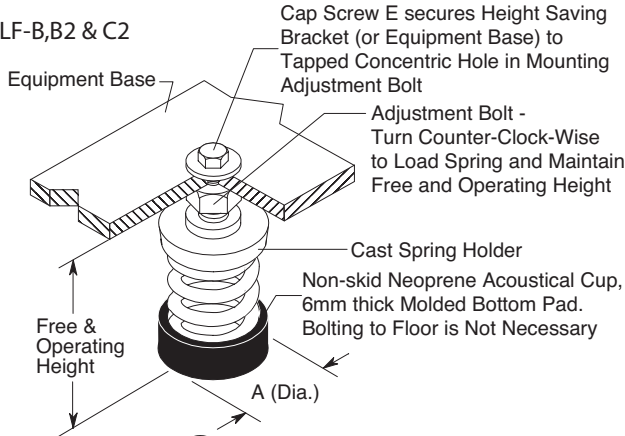

SLF-2C2

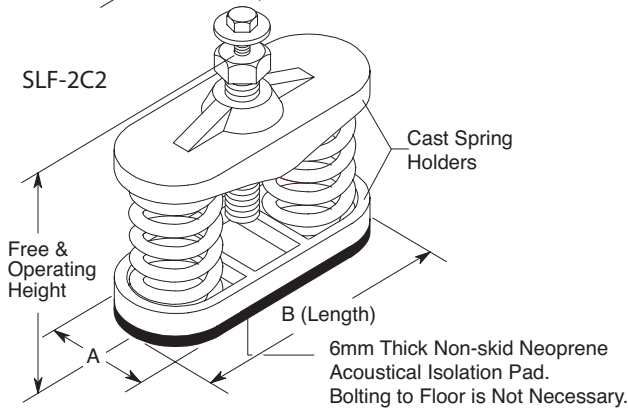

TYPE SLF DIMENSIONS (mm)

Size	Free & Oper Height	A	B	Locking Cap Screw E	SPRING DATA			
					Spring OD	Free HT.	Ratio Kx/Ky	Ratio OD/OH
SLF-B & B2	171	70	—	1/2"x1 1/4"	70	102-114	0.55-0.90	0.79-1.18
SLF-C2	171	83	—	1/2"x1 1/4"	73	127	0.63-0.85	0.96-1.15
SLF-2-C2	171	83	197	1/2"x1 1/4"	73	127	0.63-0.85	0.96-1.15

SLF-B2-450, B2-680, C2-880 thru C2-1870 & 2-C2-1760 thru 2-C2-3740 mounts have minimum 25% of rated deflection additional travel to solid. The last two columns below show ratings at 50% additional travel.

TYPE SLF RATINGS

*with RED core spring

Size	Standard Ratings				Ratings at 50% additional travel to solid	
	Rated Capacity (kg)	Rated Defl (mm)	Mount Constant (kg/mm)	Spring Color/Stripe	Capacity (kg)	Defl (mm)
SLF-B-20	9	61	0.2	Tan	9	61
SLF-B-26	12	55	0.2	White/Blue	12	55
SLF-B-35	16	56	0.3	Purple	16	56
SLF-B-50	23	56	0.4	White/Red	23	56
SLF-B-65	29	53	0.5	Brown	29	53
SLF-B-85	39	53	0.7	White/Black	39	53
SLF-B-115	52	50	1.0	Silver	52	50
SLF-B-150	68	50	1.4	Orange	68	50
SLF-B2-210	95	53	1.8	Silver	95	53
SLF-B2-290	131	50	2.6	Blue	131	50
SLF-B2-450	204	50	4.0	Tan	186	46
SLF-B2-680	308	50	6.0	Gray	256	42
SLF-C2-125	57	64	0.9	Purple	57	64
SLF-C2-170	77	61	1.3	Brown	77	61
SLF-C2-210	95	58	1.6	Red	95	58
SLF-C2-260	118	56	2.1	White	118	56
SLF-C2-330	149	50	2.9	Black	149	50
SLF-C2-460	208	50	4.1	Blue	208	50
SLF-C2-610	276	50	5.5	Green	276	50
SLF-C2-880	399	50	8.0	Gray	362	46
SLF-C2-1210	548	50	11.0	Silver	457	42
SLF-C2-1540	698	50	14.0	Gray	582	42
SLF-C2-1870	847	50	17.0	Silver	706	42
SLF-2-C2-340	170	61	2.5	Brown	154	61
SLF-2-C2-420	190	58	3.3	Red	190	58
SLF-2-C2-520	236	56	4.2	White	236	56
SLF-2-C2-660	298	50	5.9	Black	299	50
SLF-2-C2-920	416	50	8.3	Blue	417	50
SLF-2-C2-1220	552	50	11.0	Green	552	50
SLF-2-C2-1760	798	50	16.0	Gray	725	46
SLF-2-C2-2420	1096	50	22.0	Silver	915	42
SLF-2-C2-3080	1396	50	28.0	Gray	1164	42
SLF-2-C2-3740	1694	50	34.0	Silver	1413	42

Multiple spring mounts have C size springs. SLF-2 indicates 2 springs.

CERTIFICATION DATA

_____ mm SPECIFIED DEFLECTION

TAG _____

UNIT _____

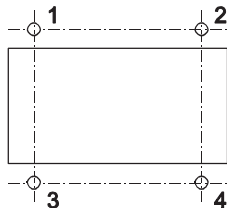

PLAN VIEW OF MOUNT LOCATION

1	2
3	4
5	6
7	8
9	10

MATERIAL FOR ONE SET _____ SETS REQUIRED

DWN	CHKD	DATE
-----	------	------

DWG No.
