



MASON INDUSTRIES, Inc.

Manufacturers of Vibration Control Products

350 Rabro Drive 2101 W. Crescent Ave., Suite D
 Hauppauge, NY 11788 Anaheim, CA 92801
 631/348-0282 714/535-2727
 FAX 631/348-0279 FAX 714/535-5738
 Info@Mason-Ind.com Info@MasonAnaheim.com
 www.Mason-Ind.com www.MasonAnaheim.com

CERTIFIED FOR _____

JOB NAME _____

CUSTOMER _____

CUSTOMER P.O. _____

MASON M. _____ DWG No. _____

TYPE
NPS
 NEOPRENE
 PARTITION
 SUPPORTS

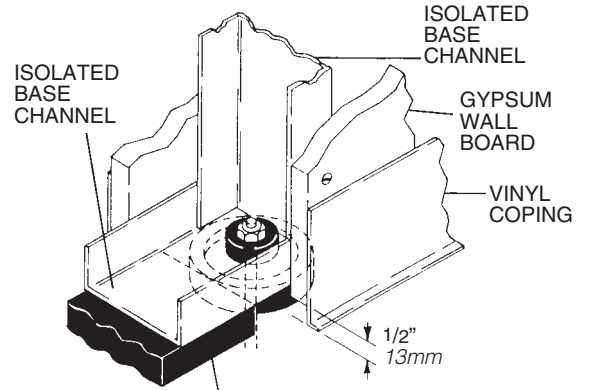
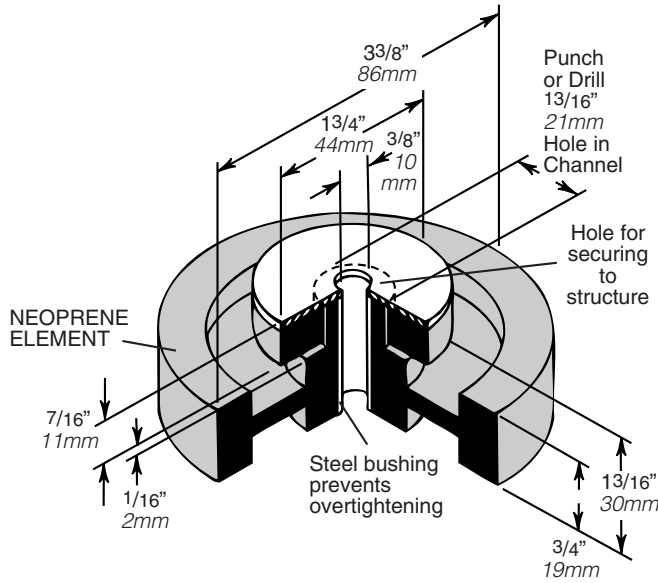

OPTIONAL 3/4" 19mm CLOSED CELL NEOPRENE OR VINYL TO IMPROVED ACOUSTICAL LOSS

NPS LOAD RATINGS

NPS Size	Durometer	Color Code	RATED LOAD		Max Static Defl.	
			lbs	kilos	in	mm
30	30	Black	140	64	0.12	2.8
40	40	Green	240	109	0.12	2.8

CERTIFICATION DATA

DWN	CHKD	DATE
-----	------	------

DWG No. _____