



MASON INDUSTRIES, Inc.

Manufacturers of Vibration Control Products
 NY Mailing Address: PO Box 410, Smithtown, NY 11787
 350 Rabro Drive 2101 W. Crescent Ave., Suite D
 Hauppauge, NY 11788 Anaheim, CA 92801
 631/348-0282 714/535-2727
 FAX 631/348-0279 FAX 714/535-5738
 Info@Mason-Ind.com Info@MasonAnaheim.com

CERTIFIED FOR

JOB NAME :
 CUSTOMER :
 CUSTOMER P.O. :
 MASON M.I. :
 DWG. NO. :

TYPE

WBI & WBD

25,50,75,100mm Deflection
 Horizontal
 Thrust Restraints

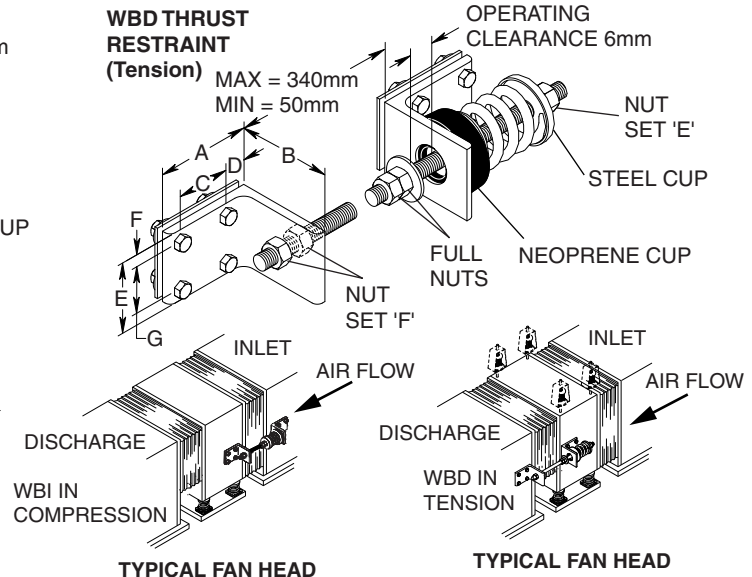
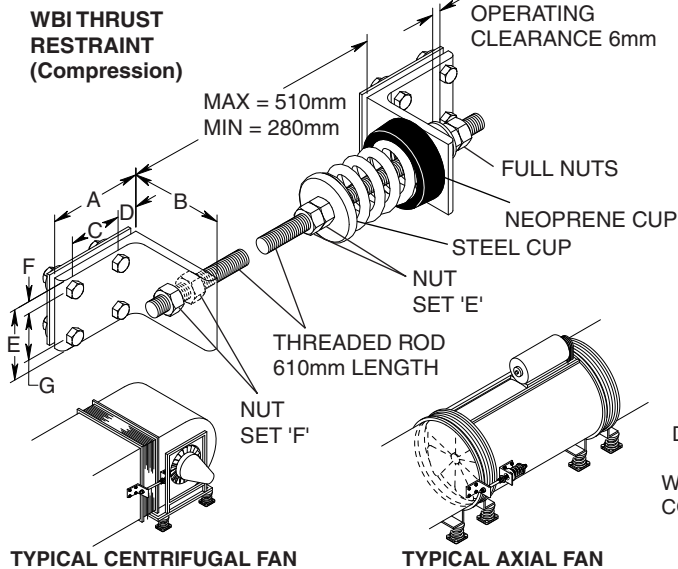

Fans Heads are cabinets containing a fan and motor and no accessories such as coils or filters. They can develop extremely high thrusts that are equal to the suction area multiplied by the negative head plus the positive pressure multiplied by the discharge area. These forces act horizontally, opposite to the airflow and about halfway up the cabinet. Since fan heads are light and narrow they tend to shift and overturn with damage to the flexible connections or to the units themselves.

Thrust restraints are recommended for all fan heads and for axial or centrifugal fans when the air thrust exceeds 10% of the equipment weight.

Type WBI and WBD Thrust Restraints are precompressed assemblies designed to withstand these forces and allow only minor motion. The WBI is considered standard and used in compression across the inlet flexible connection on both sides. The WBD design is used in tension across the discharge when WBI is impractical. We furnish all parts except those noted "by others".

One end of either the WBI or WBD Assembly must be attached to the unit. The other end is normally attached to the ductwork or adjacent section, but when this becomes difficult it can be attached to a ceiling or floor stanchion fabricated for this purpose.

WBI Units can be converted to WBD by reversing the spring assembly on the angle as illustrated.

- ### INSTALLATION INSTRUCTIONS
- 1) Check with air handling unit manufacturer to establish the structural integrity of the unit and to determine their recommendation as to the bolting position.
 - 2) Install Unit on Mounting or suspend from Hangers.
 - 3) Bolt thrust assembly angle brackets with back-up plates to fan cabinet on the centerline of the inlet (approximately halfway up the unit). Bolt second angle bracket with back-up plates to the plenum or coil section as shown. If overall length is more than needed, loosen nutset "F", slide angle on threaded rod and re-tighten.
 - 4) Turn the unit on.
 - a) If the operating clearance between angle and washer exceeds 6mm, turn nut "E" clockwise (to load spring) two turns at a time on each assembly, until clearance is 6mm
 - b) If the operating clearance between angle and washer is less than 6mm, turn nut "E" counterclockwise (to unload spring) two turns at a time on assembly, until clearance is 6mm.
 - 5) When unit is shut down on 6mm operating clearance will disappear and reappear when operation is renewed.

TYPE WBI & WBD DIMENSIONS (metric)

Type	Size	A (mm)	B (mm)	C (mm)	D (mm)	E (mm)	F (mm)	G (mm)	Threaded Rod	Max Restraint (kg/Pair)	Max Fan Head Inlet* (M ²)	Max Axial Fan Discharge Area** (M ²)	TYPE WBI & WBD RATINGS			
													Rated Capacity (kg)	Rated Defl. (mm)	Spring Constant (kg/mm)	Spring Color/Stripe
WBD	A-310	89	75	44	32	75	13	50	1/2-13NC	280	2.4	1.8	140	25	5.6	YELLOW
	B-750	100	89	57	32	75	13	50	5/8-11NC	680	6.0	4.4	340	28	12.1	WHITE
	B-1000	100	89	57	32	75	13	50	5/8-11NC	910	8.0	6.0	455	25	18.2	BLUE
	B2-290	100	89	57	32	75	13	50	5/8-11NC	265	2.3	1.7	130	50	2.6	BLUE
	B2-450	100	89	57	32	75	13	50	5/8-11NC	410	3.5	2.7	205	50	4.1	TAN
	B2-680	100	89	57	32	75	13	50	5/8-11NC	620	5.3	4.1	310	50	6.2	GRAY
	129	150	150	98	38	125	16	95	5/8-11NC	470	4.2	3.1	235	83	2.8	GREEN
	153	200	175	125	57	165	25	114	5/8-11NC	480	4.2	3.2	240	110	2.2	GREEN

*Based on 150mm pressure differential across unit with 115mm negative pressure **Based on 150mm pressure differential

CERTIFICATION DATA

_____ mm SPECIFIED DEFLECTION

DWN : _____ CHKD: _____ DATE : _____

DWG NO. : _____