



**MASON INDUSTRIES, Inc.**

Manufacturers of Vibration Control Products

NY Reply to: PO Box 410, Smithtown, NY 11787

350 Rabro Drive 2101 W. Crescent Ave., Suite D  
 Hauppauge, NY 11788 Anaheim, CA 92801  
 631/348-0282 714/535-2727  
 FAX 631/348-0279 FAX 714/535-5738  
 Info@Mason-Ind.com Info@MasonAnaheim.com

CERTIFIED FOR

JOB NAME : \_\_\_\_\_

CUSTOMER: \_\_\_\_\_

CUSTOMER P.O.: \_\_\_\_\_

MASON M.I.: \_\_\_\_\_

DWG. NO.: \_\_\_\_\_

TYPE

**UC**

SEISMIC ROD  
 CLAMPS FOR  
 STRUT CHANNELS

NOTE: For use with 1 5/8 x 1 5/8 Strut Channels

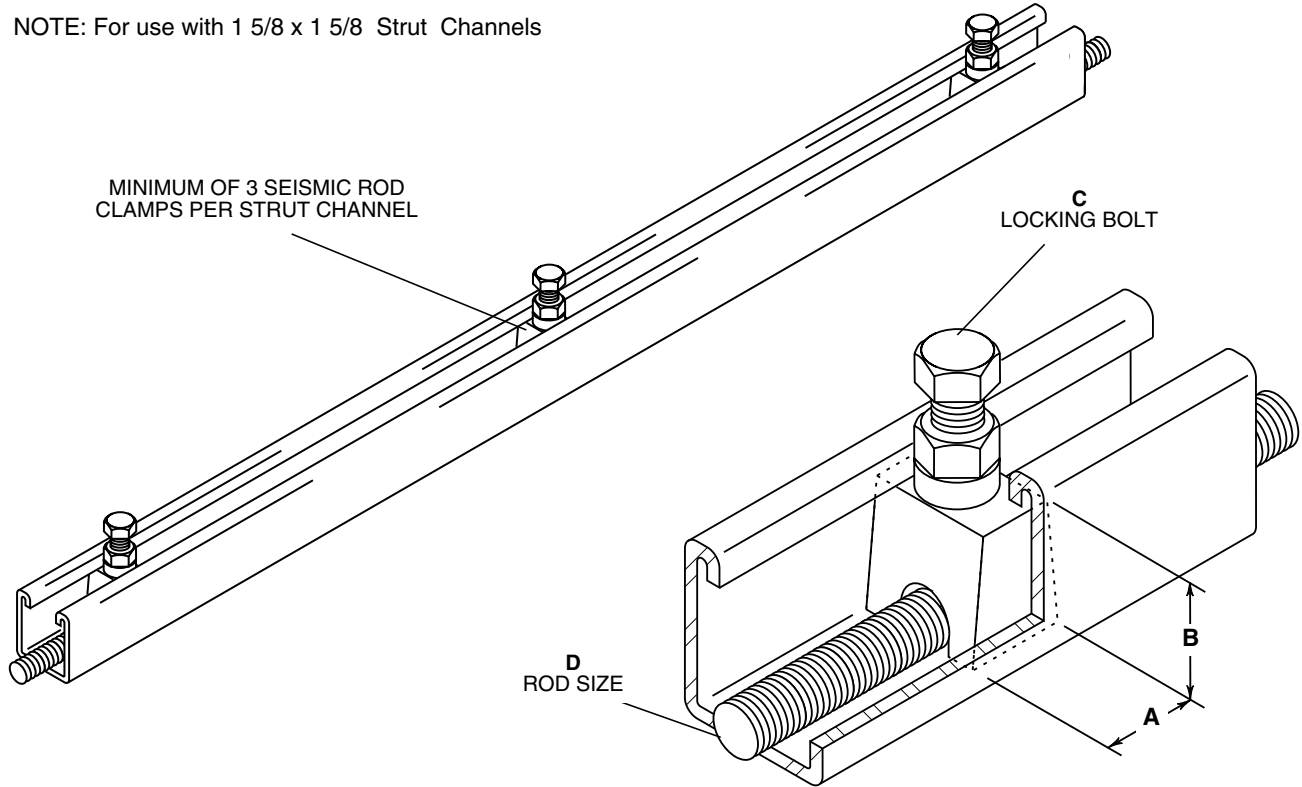

TYPE UC DIMENSIONS inches (mm)

Size	A	B	C	D Acceptable Rod Sizes
UC-1	1 (25)	1 1/8 (28)	3/8"-16 UNC	3/8 to 1/2 (10-13)
UC-2	1 1/4 (32)	1 1/8 (28)	1/2"-13 UNC	5/8 to 3/4 (16-19)

**APPROVED**

California Office of Statewide  
 Health Planning and Development  
**FIXED EQUIPMENT ANCHORAGE**  
**OPA-0349 AUGUST 5, 2002**

\*Valid for 3 Years Maximum

*Bill Staehlin*  
 Bill Staehlin (916) 654-3362

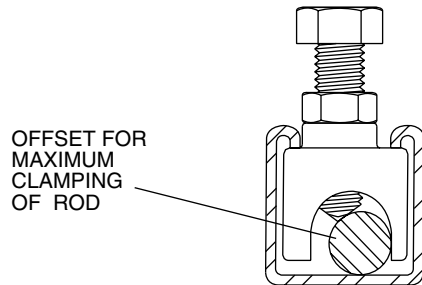
**CERTIFICATION DATA**

TAG : \_\_\_\_\_

UNIT: \_\_\_\_\_

DWN : \_\_\_\_\_ CHKD: \_\_\_\_\_ DATE : \_\_\_\_\_

DWG No. \_\_\_\_\_