



MASON INDUSTRIES, Inc.

Manufacturers of Vibration Control Products

NY Reply to: PO Box 410, Smithtown, NY 11787

350 Rabro Drive 2101 W. Crescent Ave., Suite D
 Hauppauge, NY 11788 Anaheim, CA 92801
 631/348-0282 714/535-2727
 FAX 631/348-0279 FAX 714/535-5738
 Info@Mason-Ind.com Info@MasonAnaheim.com

CERTIFIED FOR

JOB NAME : _____

CUSTOMER: _____

CUSTOMER P.O.: _____

MASON M.I.: _____

DWG. NO. : _____

TYPE

SLDB

SEISMIC LOAD DISTRIBUTION BRACKET

The SLDB is used to distribute the seismic load of solid or cable braces attached to a ceiling.

SLDB may be manufactured with or without slots.

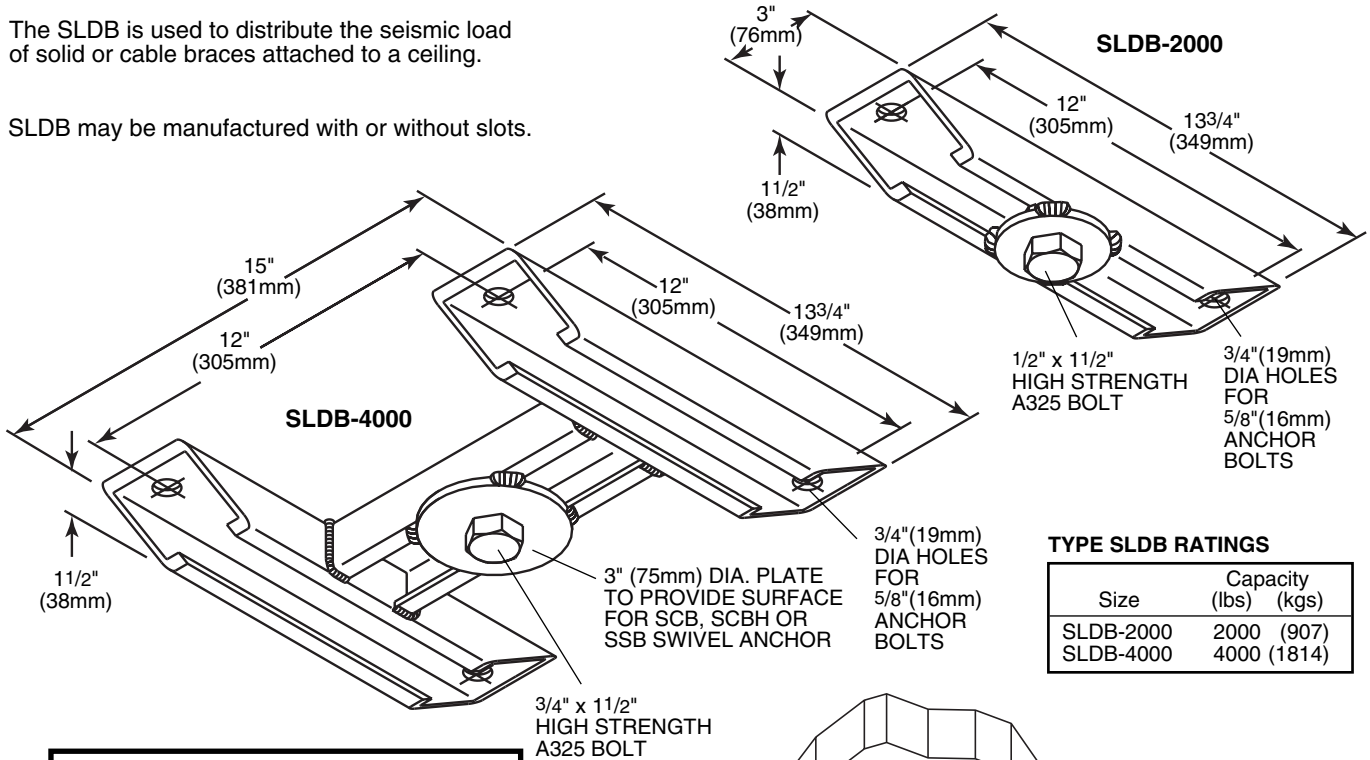

TYPE SLDB RATINGS

Size	Capacity (lbs) (kgs)
SLDB-2000	2000 (907)
SLDB-4000	4000 (1814)

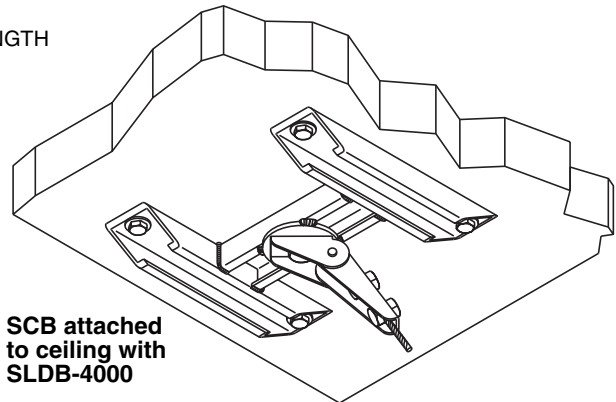

APPROVED

California Office of Statewide
 Health Planning and Development

FIXED EQUIPMENT ANCHORAGE
OPA-0349 AUGUST 5, 2002

*Valid for 3 Years Maximum

Bill Staehlin
 Bill Staehlin (916) 654-3362

CERTIFICATION DATA

TAG : _____

UNIT: _____

DWN	CHKD	DATE
-----	------	------

DWG No. _____