



MASON INDUSTRIES, Inc.
Manufacturers of Vibration Control Products

350 Rabro Drive 2101 W. Crescent Ave., Suite D
Hauppauge, NY 11788 Anaheim, CA 92801
631/348-0282 714/535-2727
FAX 631/348-0279 FAX 714/535-5738
Info@Mason-Ind.com Info@MasonAnaheim.com

CERTIFIED FOR

JOB NAME :
CUSTOMER :
CUSTOMER P.O. :
MASON M.I. :
DWG. NO. :

TYPE
LEVELING VALVE

AIR SPRING ASSEMBLY

It is strongly recommended that all Air Springs are installed with Air Spring leveling Valves

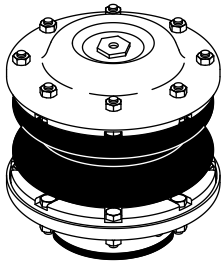

MT
Twin Sphere
Air Spring

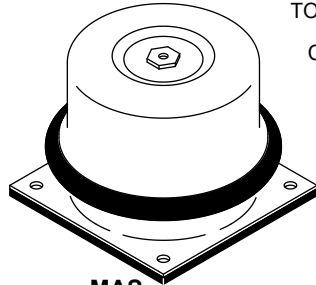

MAS
Rolling Lobe
Air Spring

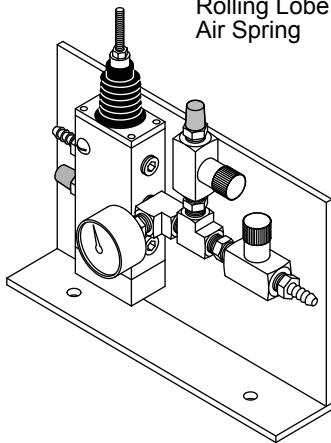

TO AIR SUPPLY
& EXHAUST
CONNECTION

AIR SUPPLY
(BY OTHERS)
100 psi [7 kg/cm²]

EXHAUST TO
ATMOSPHERE

EQUIPMENT
MOUNTING
BRACKET

AIR SUPPLY
AND EXHAUST
LEVER

CL OF ROTARY
VALVE
MECHANISM

SELF
LOCKING
NUT

TURN BUCKLE FOR
HEIGHT AND
LEVELING
ADJUSTMENT
ACCURACY ±1/8" [3]

SELF
LOCKING
NUT

If equipment loses elevation
-1/8" [3], Valve supplies air.

If equipment lifts -1/8" [3]
Valve exhausts air.

FLOOR
MOUNTING
PLATE

See Cert Sheets S-300-3, S-301-3, S-303-2
S-278-3 & S-279-2 For Additional Information

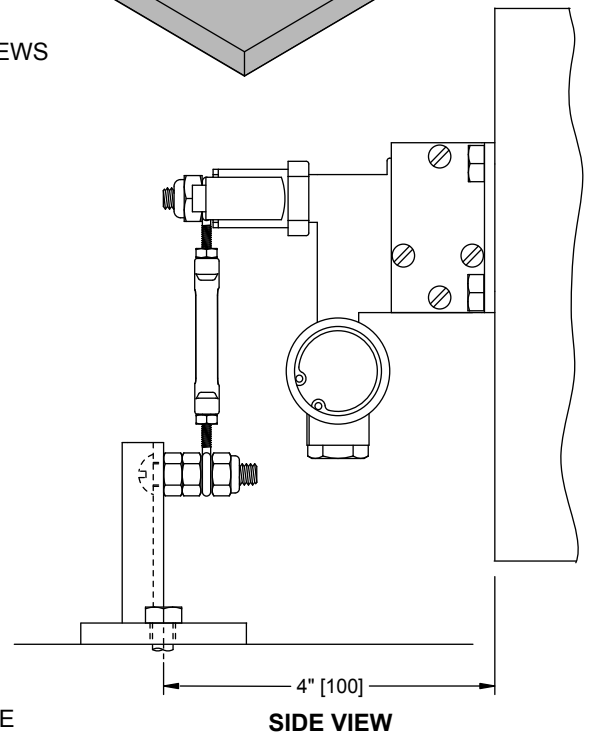
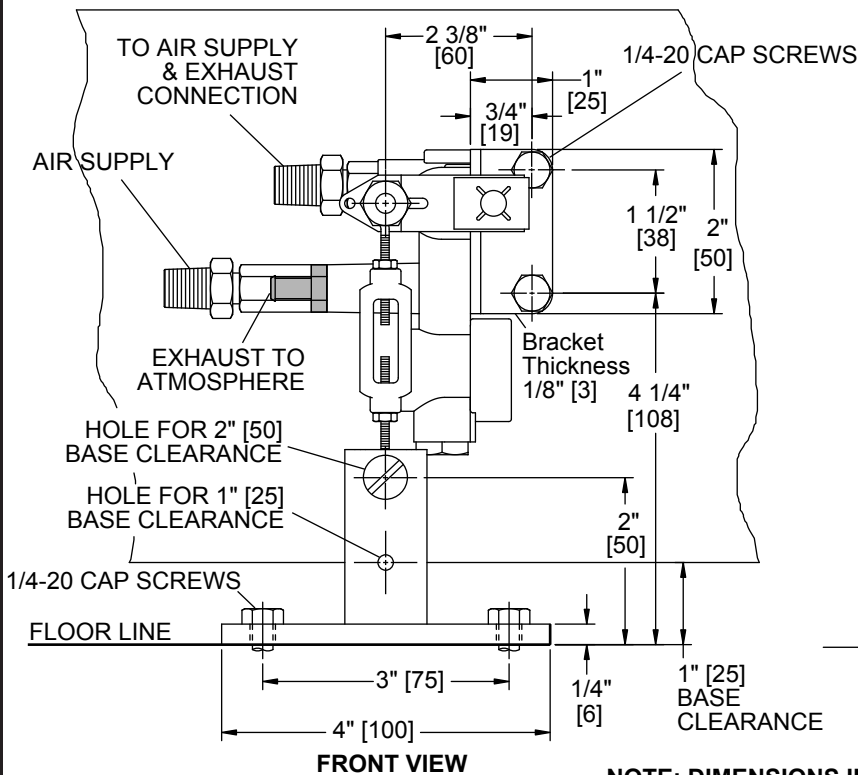

NOTE: DIMENSIONS IN BRACKETS ARE MILLIMETERS.

DWN : CHKD : DATE :

DWG NO. :