



MASON INDUSTRIES, Inc.

Manufacturers of Vibration Control Products

NY Reply to: PO Box 410, Smithtown, NY 11787

350 Rabro Drive 2101 W. Crescent Ave., Suite D
 Hauppauge, NY 11788 Anaheim, CA 92801
 631/348-0282 714/535-2727
 FAX 631/348-0279 FAX 714/535-5738
 Info@Mason-Ind.com Info@MasonAnaheim.com

CERTIFIED FOR

JOB NAME _____

CUSTOMER _____

CUSTOMER P.O. _____

MASON M.I. _____ DWG No. _____

TYPE

JAH

Joist
Attachment
Hardware

The JAH is used to attach solid or cable braces to the top cord of bar joists. Attachment to the lower cord is not recommended.

"E" TAPPED HOLE IN DUCTILE IRON CASTING. BOLT BY OTHERS.

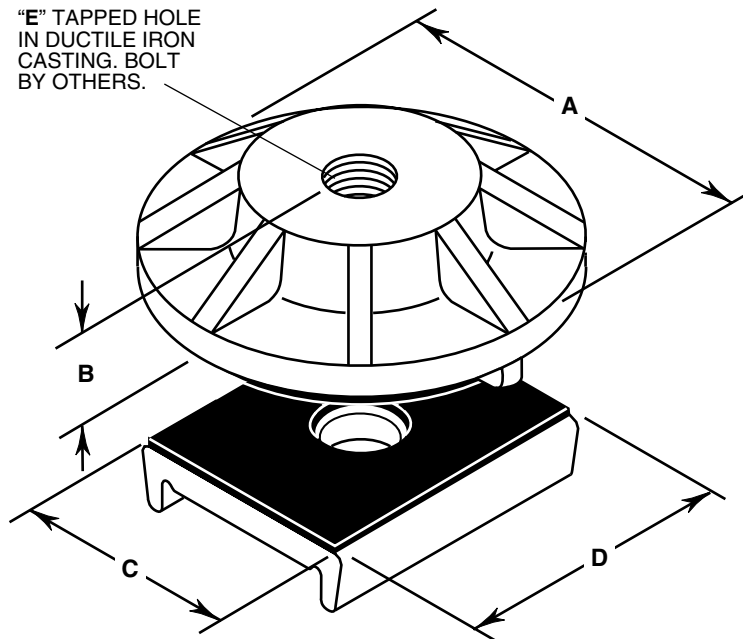

SCB ATTACHED TO TOP OF JOIST WITH JAH

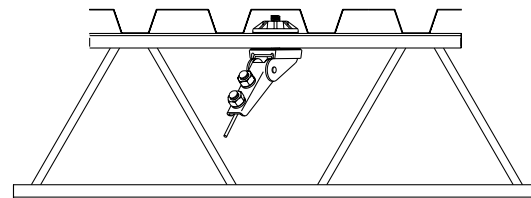

BOLT LENGTH IS ANGLE LEG LENGTH PLUS 1 1/2" (40mm) MINIMUM

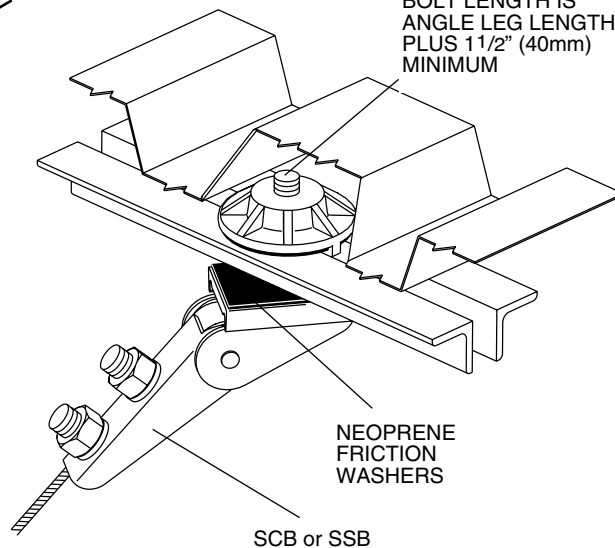

NEOPRENE FRICTION WASHERS

SCB or SSB

TYPE JAH DIMENSIONS inches (mm)

Size	SCB/SSB Size	A	B	C	D	E	Max. Load lbs (kgs)	
							SCB	SSB
JAH-1	SCB/SSB-1	3 (76)	3/4 (19)	17/8 (48)	2 1/4 (57)	1/2-13UNC	975 (442)	1500 (680)
JAH-2	SCB/SSB-2	3 (76)	3/4 (19)	2 1/8 (54)	3 (76)	5/8-11UNC	2050 (930)	3000 (1361)
JAH-3	SCB/SSB-3	3 (76)	3/4 (19)	2 1/2 (64)	3 3/4 (95)	3/4-10UNC	3150 (1429)	5000 (2268)

CERTIFICATION DATA

DWN	CHKD	DATE
-----	------	------

DWG No.
