

MASON INDUSTRIES, Inc.

Manufacturers of Vibration Control Products
 NY Mailing Address: PO Box 410, Smithtown, NY 11787
 350 Rabro Drive 2101 W. Crescent Ave., Suite D
 Hauppauge, NY 11788 Anaheim, CA 92801
 631/348-0282 714/535-2727
 FAX 631/348-0279 FAX 714/535-5738
 Info@Mason-Ind.com Info@MasonAnaheim.com

CERTIFIED FOR

JOB NAME :
 CUSTOMER :
 CUSTOMER P.O. :
 MASON M.I. :
 DWG. NO. :

TYPE

HPA

HOUSEKEEPING
 PAD
 ANCHOR

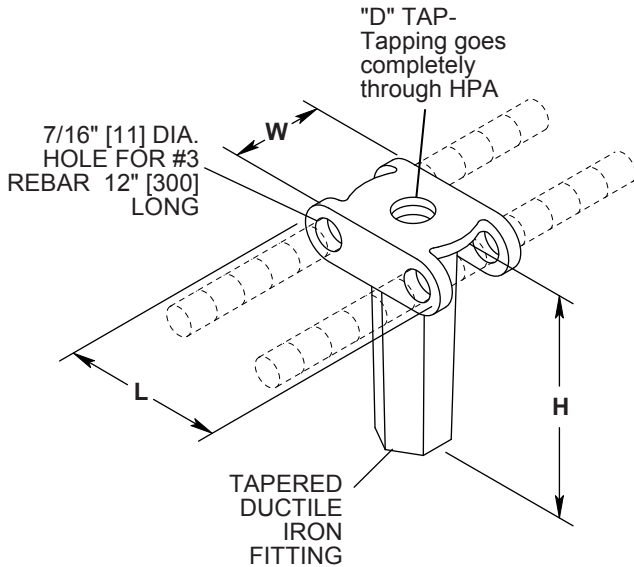

TYPE HPA DIMENSIONS

Size	L	W	H	D
HPA-1/2	2 1/8 [54]	1 1/4 [32]	3 [75]	1/2-13 UNC
HPA-5/8	2 3/8 [60]	1 1/2 [38]	3 [75]	5/8-11 UNC
HPA-3/4	2 3/4 [70]	1 3/4 [44]	3 [75]	3/4-10 UNC

NOTE: Dimensions in Brackets are Millimeters.

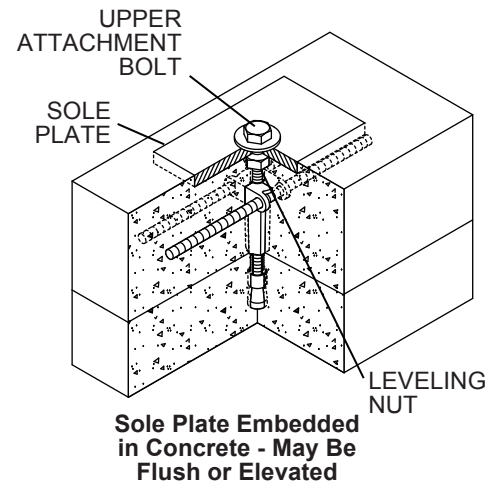
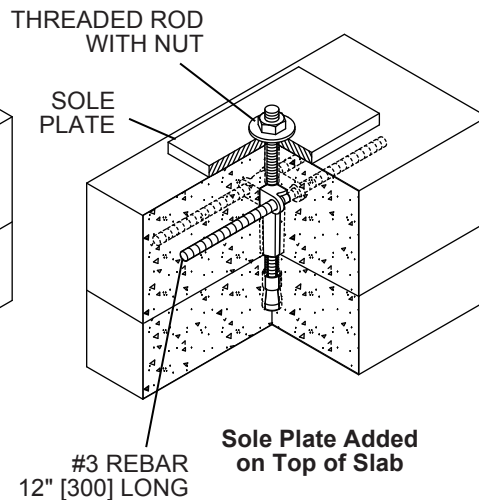
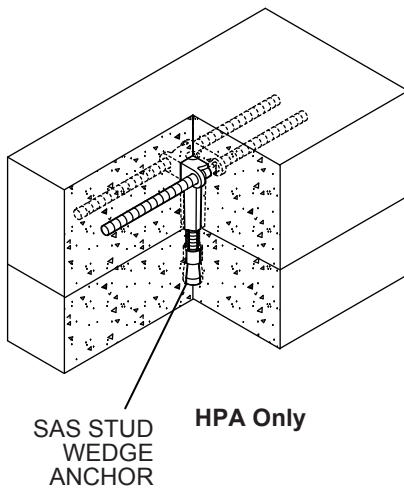

CERTIFICATION DATA

TAG: _____

UNIT: _____

HPA Size _____

No. of HPA _____

Recommended Reinforcing _____

Housekeeping
Pad Thickness _____

Minimum Housekeeping
Pad Thickness of 4"

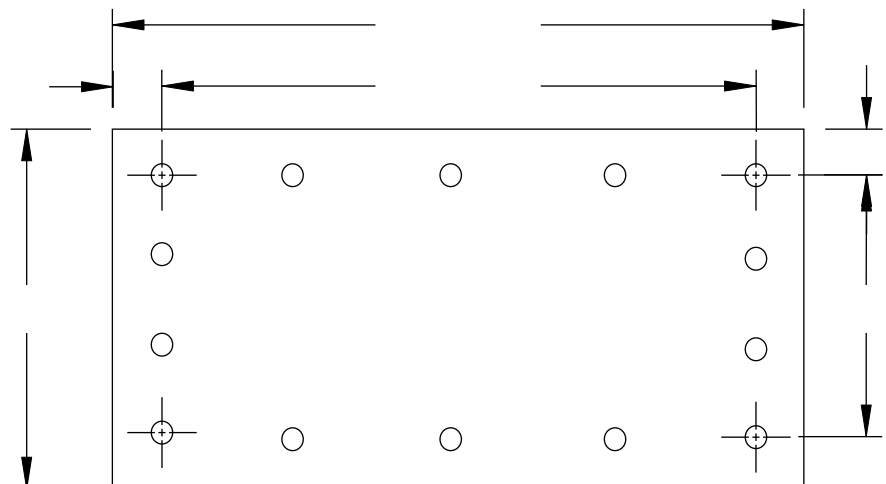

PLAN VIEW OF HOUSE KEEPING PAD

DWN : _____ CHKD: _____ DATE : _____

DWG NO. : _____