



MASON INDUSTRIES, Inc.
Manufacturers of Vibration Control Products
 NY Mailing Address: PO Box 410, Smithtown, NY 11787
 350 Rabro Drive 2101 W. Crescent Ave., Suite D
 Hauppauge, NY 11788 Anaheim, CA 92801
 631/348-0282 714/535-2727
 FAX 631/348-0279 FAX 714/535-5738
 Info@Mason-Ind.com Info@MasonAnaheim.com

CERTIFIED FOR

JOB NAME :
 CUSTOMER :
 CUSTOMER P.O. :
 MASON M.I. :
 DWG. NO. :

TYPE

DP

Dash Pot
 Viscous Fluid
 Dampers

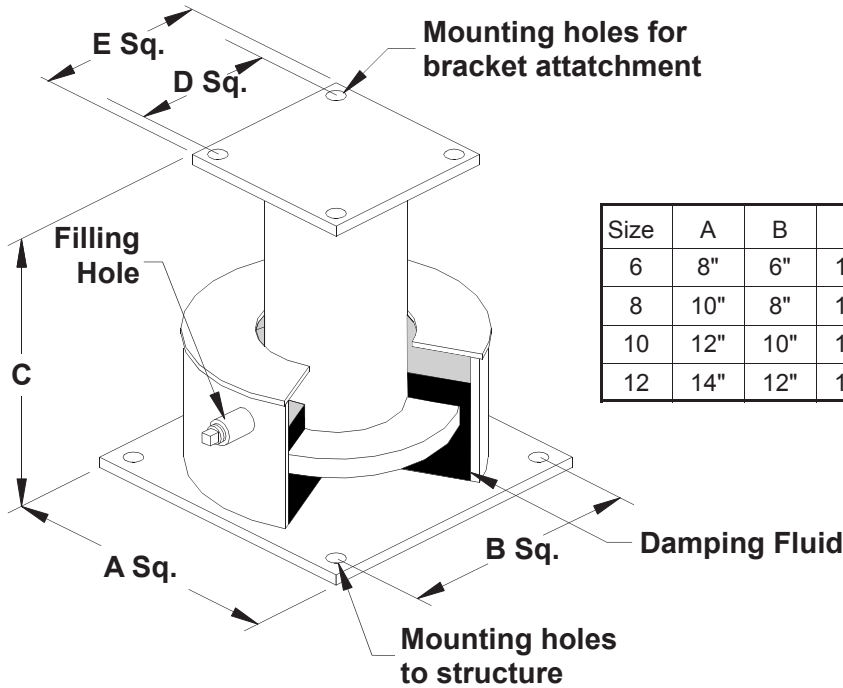

Size	A	B	C	D	E	Damping-Constant (C)
6	8"	6"	12"	2 1/2"	4"	5 - 10#/In/Sec
8	10"	8"	12"	3"	4 1/2"	10 - 55#/In/Sec
10	12"	10"	12"	5"	6 1/2"	60 - 90#/In/Sec
12	14"	12"	12"	7"	8 1/2"	110 - 140#/In/Sec

1. Standard dampers have 6, 8, 10 & 12 inch cylinder diameters.
2. Piston diameters are designed by Mason Industries based on system damping requirements.
3. The standard damping fluid has a viscosity of 30,000 cs. Other fluids may be used with a maximum viscosity of 100,000 cs. Silicone fluids insure viscosity stability thru the broadest possible temperature change.
4. Other sizes are custom designed as required.

CERTIFICATION DATA

TAG : _____

UNIT : _____

DWN : _____ CHKD: _____ DATE : _____

DWG NO. : _____